

Young Joseph

The Life of Joseph
Lesson 1

Lesson Objectives

- The children will tell the story of young Joseph.
- The children will describe one way that Joseph felt special.
- The children will describe one way that they are special to God.

Lesson Text

Genesis 37:1-11

Scripture Memory Verse

Don't let anyone look down on you because you are young, but set an example for the believers.

1 Timothy 4:12

Lesson Plan

Greeting and Registration

Preclass Activity: Color Coated

Welcome and Singing

Centers:

Bible Story: Young Joseph

Craft: Coat of Many Colors

Scripture Memory: Look Out Below!

NOTE: Allow time for a snack.



Young Joseph

Color Coated

The children will make strips of colored paper to be used later in their craft to make a coat of many colors.

Materials

For each child:

- 5 pieces of colored construction paper
- scissors
- crayons or markers

For the teacher:

- 1 medium bag or box
- scissors

Preparation

Decorate and cut out one set of construction paper strips to show the children as an example.

Instructions

NOTE: Display the sample Coat of Many Colors from the Craft Center for the children to see.

1. As the children arrive, show them the strips that you have prepared. Tell the children that today they will learn about a man named Joseph, who had an ornamented robe. Explain that an ornament is something used for decorations, like Christmas ornaments. The strips they make during Preclass will be the ornaments for a special coat they will make for their craft.
2. Distribute crayons, scissors, and construction paper. Encourage the children to color the paper first with designs, patterns or pictures, and then cut the strips. The children may cut the strips with straight lines or with wavy lines or using other patterns.

3. Have each child prepare at least five pieces of construction paper, or at least thirty strips, and place them all in the bag or box that you brought.
4. Give the paper strips to the Craft teacher to be used during the Craft time.
5. Circulate among them to offer help.
6. Encourage the children who finish early to prepare extra strips for any children who may arrive late.

Teacher Tips

- Consider additional ways to ornament the paper strips.

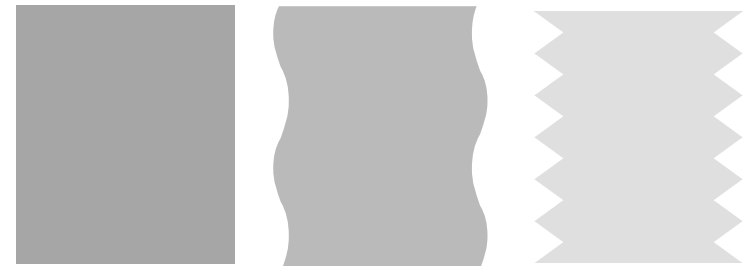

B

Young Joseph

S

Young Joseph

The children will learn and tell different ways that Joseph felt special.

I

Materials

For the teacher:

- a blanket
- a framed family picture
- a small pillow
- a medal, award or prize (can be your own or someone else's)
- large bag or box

T

B

Preparation

1. Practice telling the Bible Story using the props with emphasis and enthusiasm.
2. Place the picture, pillow and prize in the large bag or box.
3. Place the blanket on the floor and in a corner of your story area.

O

L

Introducing the Bible Story

Direct the children to sit on the blanket in the story area, facing you. Explain that today they will hear about Joseph, who was one of Jacob's sons. Tell the children that Joseph was a very special person and today they are going to find out why.

R

Joseph's Family

Have your Bible open to Genesis 37. Tell the children that today's Bible Story comes from Genesis 37. *Joseph was seventeen years old when this story begins. He was a shepherd and he took care of the flocks. Joseph came from a large family—he had ten older brothers and one younger brother. The Bible says that Joseph was born when his father Jacob was old. Jacob loved Joseph very much, so much in fact that his brothers were jealous of him. They saw that Jacob loved Joseph more than them. Because of his love for Joseph, Jacob made a beautiful coat—a richly ornamented robe—for Joseph. When Joseph's brothers saw the beautiful coat, they were not happy. They could not even say anything nice to their brother.*

E

Y

Hold up the family picture that you brought in. Remind the children that God puts us in families and our families make us feel special. Our parents and our brothers and sisters are gifts from God. Even if they do not always treat us the way we want to be treated,

they are still a special gift from God. Joseph's brothers did not make him feel special, but Joseph's father did. His father loved him very much and that made Joseph feel very special.

Joseph's Dreams

The Bible says that Joseph had two dreams. In one dream, he was out in the field working with his brothers and they were gathering sheaves of grain. Then, his sheaf of grain stood up tall and his brothers' all gathered around his and bowed down. In the second dream, Joseph saw the sun, moon and eleven stars bowing down to him. In his dreams, Joseph had a vision that he would be a great and very powerful man. Joseph's dreams made him feel special.

Take out the pillow that you brought in. Explain that before people had Jesus and the Bible, God spoke to them in dreams. Today he does not speak to us in our sleep like he did then, but he still can put special plans and thoughts in our minds. God wants us to have great dreams for our lives. He wants us to imagine ourselves doing great things by faith for him and his church.

Joseph's Courage to Tell

The Bible says that after Joseph had his first dream, he told his brothers about it. They were unhappy with Joseph. They thought that Joseph had plans to rule over them. Since he was younger than them, this made them angry and they hated him. Then, after his second dream, Joseph again told his brothers and his father. This made his brothers even more upset and even his father spoke to him about it. They all thought that Joseph was going to try and rule over them because of his dreams.

Take out the prize or medal that you brought in. Tell the children that Joseph did not make up his dreams. He knew that they had to mean something—and he believed they meant something special. He was not afraid to tell his brothers about his dreams even though they did not like to hear them. He wanted to share his dreams with his family. He was not afraid to tell his father either. Joseph felt so special that he was not afraid to tell people about his dreams.



B

S

I

T

B

O

L

R

E

Y

Young Joseph

Share and Tell

Take out the picture, pillow and prize and give them to three children. Ask each one to tell one way that Joseph was special and one person that they are going to tell this week about Joseph. Continue until each child has had a chance. Close with a prayer for the children to each tell someone how much God loves them and how special they are to him.

Teacher Tips

- Pray for the children to know how much God loves them and to really feel special to God.

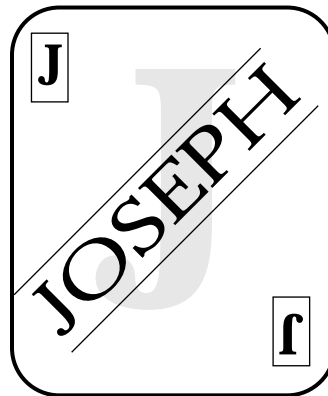

C

•
R

•
A

•
F

•
T

•
•
•

Young Joseph

Coat of Many Colors

The children will make a special coat of many colors to remind them of Joseph's ornamented robe from today's Bible Story.

Materials

For each child:

- 1 brown paper grocery bag
- 1 glue stick or masking tape

For the teacher:

- paper strips prepared during Preclass
- scissors

Reproducible Pages:

- Page A, 1 copy for each child

Preparation

1. Prepare a Coat of Many Colors to show the children as an example. Practice making the craft until you are comfortable leading the children in the directions.
2. Cut out the "_____ is Special to God" shield from copies of Reproducible Page A for each child.
3. For each child, prepare a paper bag by cutting holes in the bottom, sides and front, as shown in Figure A.

Instructions

1. *In our Bible Story, we learned that Joseph was a very special person. He was special to his father, he was special to God and he had courage to talk about some special dreams that he had. Joseph was born when his father was old, and Joseph's father loved him in an extra special way. The Bible tells us that Joseph's father gave him a special coat—or a "richly ornamented" robe. Today you are going to make a Coat of Many Colors to remind you of Joseph and our Bible Story this week.*
2. Distribute the paper bags and shields that you prepared for the children. Have the children write their names on their shields and then paste them on the backs of the paper bags, as shown in Figure B.

3. Bring out the crayons and paper strips that the children prepared during Preclass. Tell each child to take at least thirty strips and paste or tape them on their coat, as shown in Figure C. Encourage them to be creative. They may color and paste strips in whatever style they choose.
4. Offer assistance with paste and tape as needed.
5. Help the children to put on their Coat of Many Colors. Have the children stand in a circle and say, "I am special to God."

Conclusion

Encourage the children for their creative efforts. Remind them that each coat is special, just as each one of them is special. Close with a prayer thanking God for each child by name and that they will understand how special they are to God.

Teacher Tips

- Consider additional materials to decorate the coats, including: stickers, yarn, tinsel, etc.

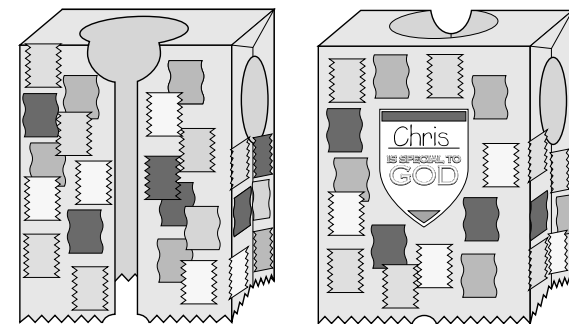

C
•
R
•
A
•
F
•
T
•
•
•

Young Joseph

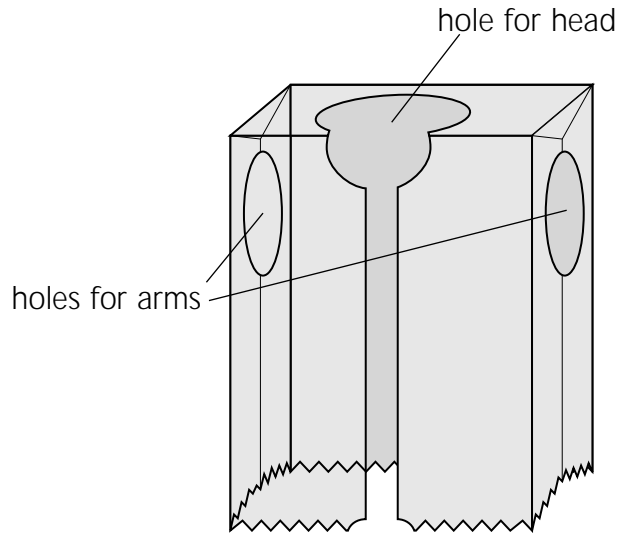

Figure A

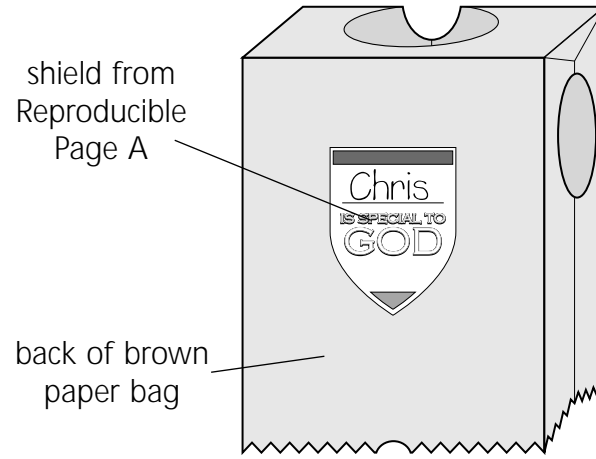

Figure B

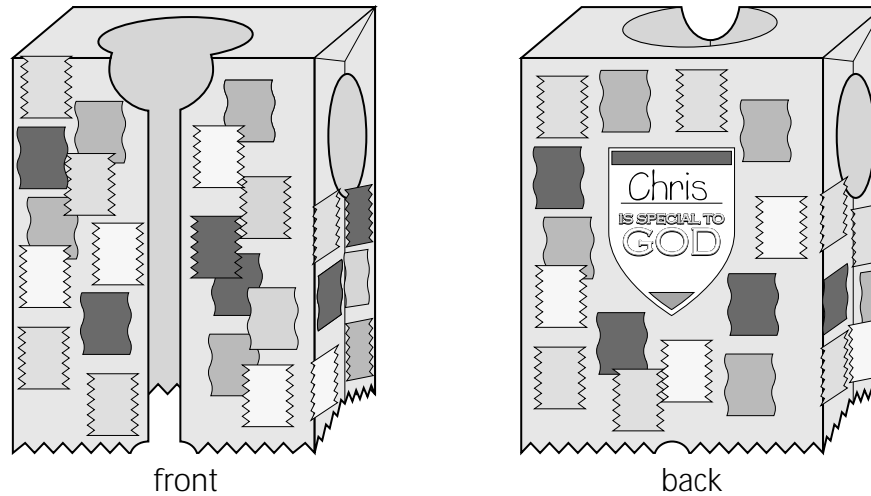

Figure C



SCR
IPT
URE
MEM
ORY

Young Joseph

Look Out Below!

The children will learn and memorize the Scripture Memory Verse through this fun activity.

Scripture Memory Verse

Don't let anyone look down on you because you are young, but set an example for the believers.

1 Timothy 4:12

Materials

For the teacher:

- 1 paper towel roll
- 1 piece of construction paper
- invisible tape
- large writing surface

Preparation

1. Learn the Scripture Memory Verse before coming to class.
2. Wrap the construction paper tightly around the paper towel roll and secure it with tape. Decorate it to look like a telescope or something creative.
3. On the large writing surface, write the verse as it appears on the back of this lesson card.

Instructions

1. Tell the children that today's Scripture Memory Verse has a very important message for them. Joseph was a young man when he had dreams of being someone special. The children should not think that they are too young to have dreams of being great for God.
2. Show the children the Scripture Memory Verse on the back of this lesson card. Say it to them once, and then have them repeat after you. Say it together with the children three times.
3. Ask the boys to say it with you and then the girls. Ask the children to stand and say it with you, and then to sit. Ask them to say it with you at a fast speed and then at a slow speed.

4. Ask each child to take turns saying it together with you.
5. Show the children the telescope that you prepared. Tell the children that each of them will take turns holding it, looking at the verse through the hole. Show them by holding it up to your eye and reading aloud the verse on the large writing surface. Let each child take a turn.
6. Cover the large writing surface and tell the children that they will now say it from memory. This time they will hold the telescope and look out toward the other children as they say the verse aloud. Have the children sit in a circle. Stand up and hold the telescope, looking down at the others and say the verse from memory.

Conclusion

Remind the children that God has always used young men and women to do great things for him. Close with a prayer for the children to understand how much God loves them and wants for them to be successful like Joseph—even while they are young.

Teacher Tips

- Be animated and enthusiastic! Think of other fun ways to use the telescope to reinforce their memory of this scripture.



Don't let anyone
look down on you
because you are young,
but set an example for
the believers.

1 Timothy 4:12

Lesson Objectives

- The children will tell the story of young Joseph.
- The children will describe one way that Joseph felt special.
- The children will describe one way that they are special to God.

Lesson Text

Genesis 37:1-11

Scripture Memory Verse

Don't let anyone look down on you because you are young, but set an example for the believers.

1 Timothy 4:12

Lesson Plan

Greeting and Registration

Preclass Activity: Great Expectations

Welcome and Singing

Centers:

Life Application: Think Thank

Game: Hot Potato Joe

Bible Skills: Twelve Is Enough!

NOTE: Allow time for a snack.



pre class

ACTIVITY

Great Expectations

The children will create a mural of Joseph's life and the things that made him feel special.

Materials

For each child:

- crayons
- magazine pictures
- scissors
- 1 glue stick

For the teacher:

- 3 pieces of banner paper, each 6'
- masking tape
- scissors

Preparation

1. Prepare the three pieces of banner paper and secure them to the workspaces with masking tape.
2. On the top of the first banner, print in large letters: Family; on the second, print:

Dreams; on the third, print: Courage.

3. Cut out magazine pictures that depict the words Family, Dreams and Courage.

Instructions

1. As the children arrive, show them the three banners that you have prepared. Explain that each banner represents a different way in which Joseph was special. Tell them that they should visit all three banners and glue or draw one picture of something that describes the word on the top of the banner.
2. Divide the children into three groups to begin and let them rotate at their own pace to all three areas. Pair the children who did not hear the Bible Story with those who did. Be available to assist with ideas. Make sure that the children sign their names under the pictures they

draw or glue.

3. Circulate between the different areas. Ask the children what they remember from this week's Bible Story.
4. When the children are finished, hang the banners in a place where they can be seen for the rest of the class.

Teacher Tips

- "Raffle" off the banners to take home or offer them to the children who ask.

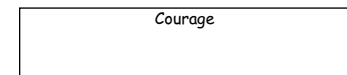
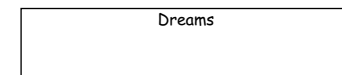
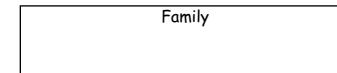

Think Thank

The children will think of ways which they are special and thank God for making them that way.

Materials

For each child:

- pencil
- crayons

For the teacher:

- large writing surface

Reproducible Pages:

- Page B, 1 copy for each child

Preparation

1. On the large writing surface, create a chart like the one on your copy of Reproducible Page B.
2. Complete your copy of Reproducible Page B.

Reviewing the Bible Story

In this week's Bible Story we learned about a young man named Joseph. Who remembers something about Joseph? (Take some responses.) He was born when his father was old. His father loved him very much and made a beautiful robe for him. His brothers were jealous of their father's love for Joseph. Joseph had two great dreams and he shared them with his brothers. Joseph's brothers thought that Joseph wanted to rule over them.

Distribute copies of Reproducible Page B and pencils to the children. Explain that you are going to complete these pages together and then say a special prayer of thanks at the end.

Time to Think

Using the large chart on the writing surface that you prepared, lead the children in the following questions:

- Ask the children to look at the box that says "Family." Ask them to think about their families. Tell them to write the names of the people in their families in that box.
- Ask the children to look at the box that says "Dreams." Ask them to think of something that they want to do for God when they grow up and write it in the box. Offer help with spelling and ideas.

- Ask the children to look at the box under the word "Courage to Tell." Ask them to think of someone whom they will need courage to tell about God this week and write the name in the box.

Time to Thank

When the children have finished filling in each box in the "Think" row, then have them sit in a circle on the floor. Tell them to hold their page in their laps. You will begin a prayer in which each child will say the things that they wrote in the box.

Lead the prayer, saying for example: *Dear God, we want to thank you for all the special ways you have blessed our lives. We want to thank you first for our families. Thank you for _____* (name the members of your family). Tell the child to your right to thank God for the people she wrote on her page. Have the children continue until all have prayed. Have them draw a smiley face in the "Thank" box.

Next, God, we want to thank you for giving us special plans and thoughts for ways we can serve you. We want you to use us to do your work, God. Please help me to _____ (share one thing you want to do for God) and tell the child on your left to continue in the same way until all the children have prayed. Have them draw a smiley face in the "Thank" box.

Finally Lord, we pray that you will give us courage to tell others like Joseph did. Please help me to tell _____ (name of someone you are reaching out to) *about you.* Tell the child to your right to continue in the same way until all the children have prayed. Close the prayer saying, *In Jesus' name we pray, Amen.* Have them draw a smiley face in the "Thank" box.

Teacher Tips

- To ensure that all the children pray, make sure that their prayers are concise. Do not force a child to pray, but rather encourage a reluctant child to listen to the other children's prayers and try the next time.

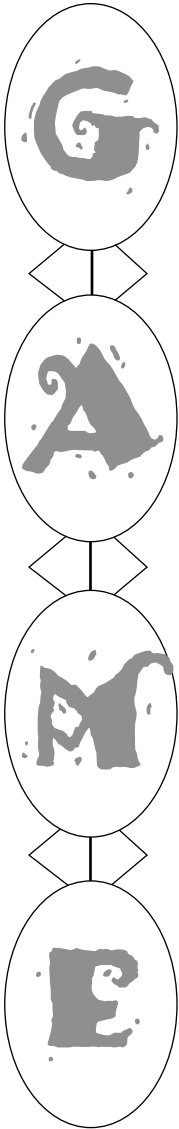

Hot Potato Joe

The children will review and describe ways that Joseph was special in this fun "hot potato" game.

Materials

For the teacher:

- small bean bag or similar object
- music



Preparation

Practice playing this game at home.

Instructions

1. Explain that today's game is a fun review of this week's Bible Story. Remind them of the story, saying: *We learned that Joseph was a special person for several reasons. Joseph was special to his father because he was born when his father was old. Joseph had some dreams when he was a young man that he would one day do great things and he believed that he was special. Joseph was not afraid to tell his family about his dreams. He had courage to believe that he was special.*
2. Organize the children in a circle. Explain that you will play some music and the children will pass the "hot potato." When the music stops, the child holding the bean bag must say in a loud voice, "Hot Potato Joe!" and then state one thing that made Joseph feel special.
3. Play continues until all the children have had an opportunity to state something that was special. For children who have already answered, they may remain in the circle and pass the bean bag to another child who has not answered.



Conclusion

Take the bean bag and say, *I am special because God gave me _____*. Then pass the bean bag to the child on you left and tell him to follow your pattern, saying one reason why he is special. After all the children have gone, close with a prayer thanking God for all the wonderful ways he has made the children so special.

Teacher Tips

- Pray that God will help you to make each child feel special.



Young Joseph

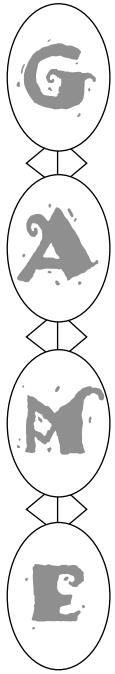

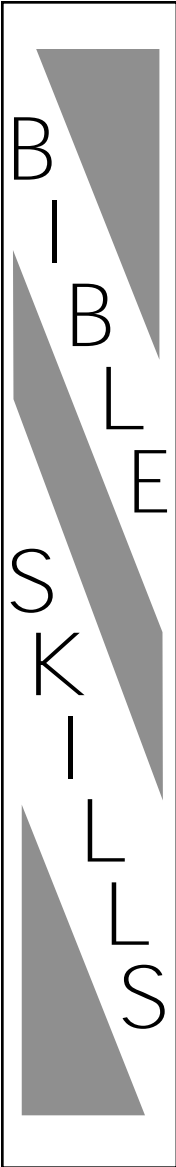

Twelve Is Enough!

The children will learn the names of Jacob's twelve sons through this fun, matching game.

Materials

For the teacher:

- 12 index cards, 3" x 5"
- scissors
- 1 glue stick

Reproducible Pages:

- Page C, 2 copies for the teacher
- Page D, 2 copies for the teacher

Preparation

1. Cut out the Jacob's Sons cards from your copies of Reproducible Pages C and D. You should have twenty-four cards, two of each.
2. Make the cards by gluing two Jacob's Sons cards to one index card and cutting it in half, as shown.
3. Practice this game at home.

Instructions

1. Remind the children that they learned about Joseph and his brothers in this week's Bible Story. Joseph had eleven brothers. In today's Bible Skills activity, the children will learn the names of the brothers in a fun, matching game.
2. Using the opposite side of this lesson card, read the names of the twelve sons of Jacob to the children. Have them repeat after you. Do this three times.
3. Show them the cards that you have prepared. Explain that there are two of each name, so that they can find matches for each one. Pass out the cards to the children. Let them go around in a circle, saying the names that are on their cards. Collect the cards and shuffle them. Pass out the cards to the children, repeating the activity with the new cards. Collect the cards.

4. Divide the children into two teams. Place the cards face down on the floor or table in four rows of six cards. Choose the team to go first. Let the first player turn over two cards. He must say the names of both cards. If they match, he may take the pair for his team and take another turn. If they do not match, he turns them over and the next team goes.
5. Play continues until all the cards have been matched. Teams count their pairs. The team with the most pairs wins.
6. For an extra challenge: collect all the cards and invite any child to try and say the twelve names from memory. Encourage all attempts. Let the children help each other.

Conclusion

Remind the children that God has given each one of us a special family. Whether we have eleven brothers like Joseph or just one, we should always be thankful. Close with a prayer in which the children each thank God for their brothers or sisters by name. For any children who may not have a sibling, they can thank God for a special cousin or other family member.

Teacher Tips

- For greater durability, consider laminating the cards or covering them with clear contact paper.

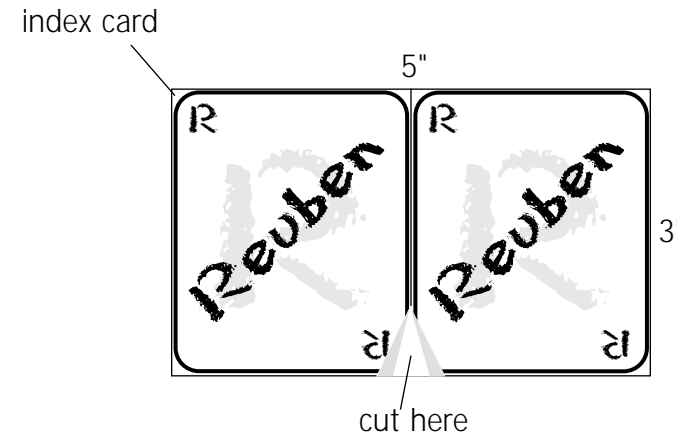



Young Joseph

Reuben

Gad

Simeon

Asher

Levi

Issachar

Judah

Zebulun

Dan

Joseph

Naphtali

Benjamin



Core/Craft
1 copy for each child

R
E
P
R
O
D
U
C
I
B
L
E

PAGE
A

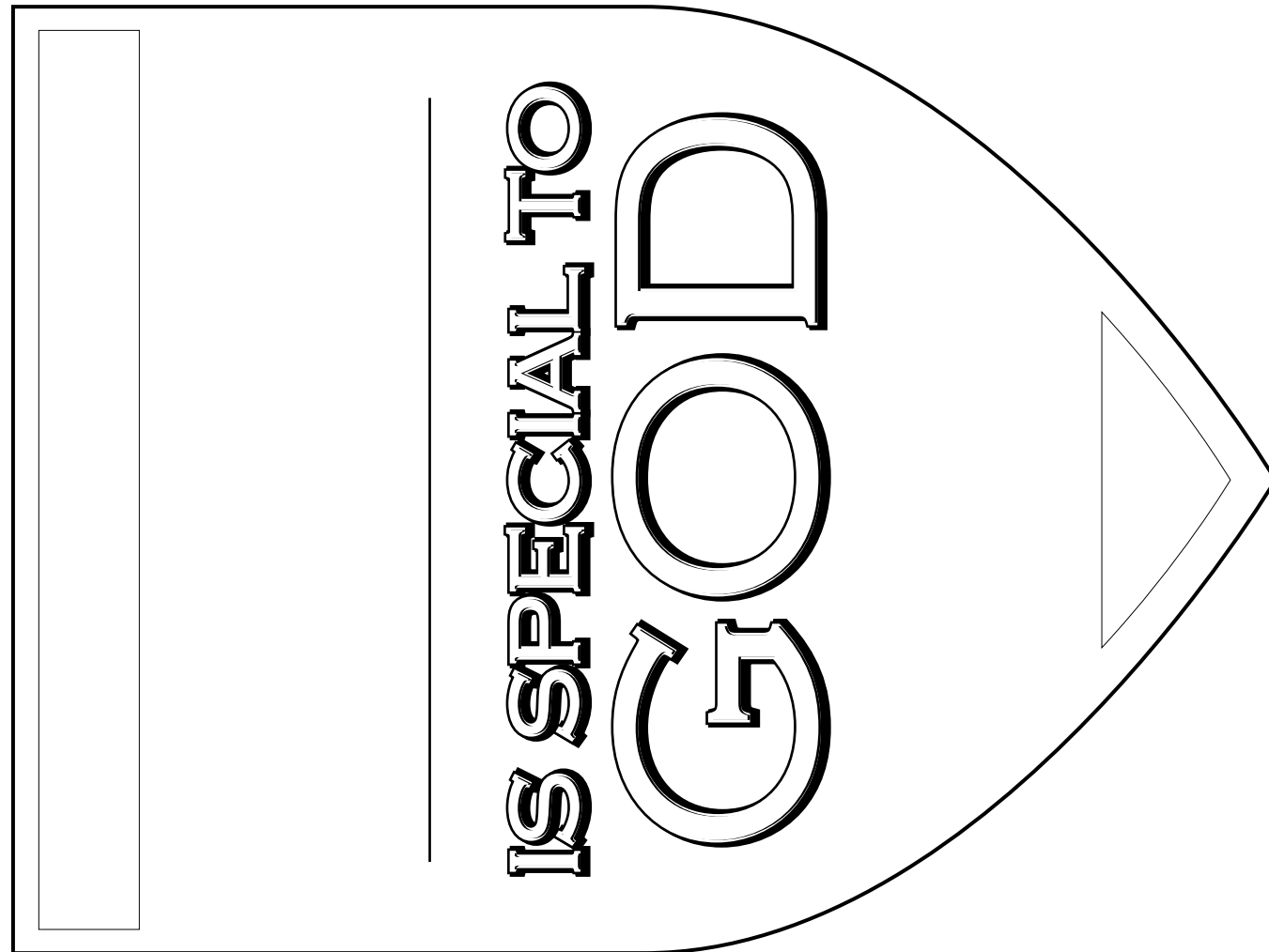

This page intentionally left blank



Supplement/Life Application
1 copy for each child

Think Thank

	Family	Dreams	Courage to Tell
Think			
Thank			

R
E
P
R
O
D
U
C
I
B
L
E

PAGE
B



Supplement/Bible Skills
2 copies for the teacher

R
E
P
R
O
D
U
C
I
B
L
E
P
A
G
E
C

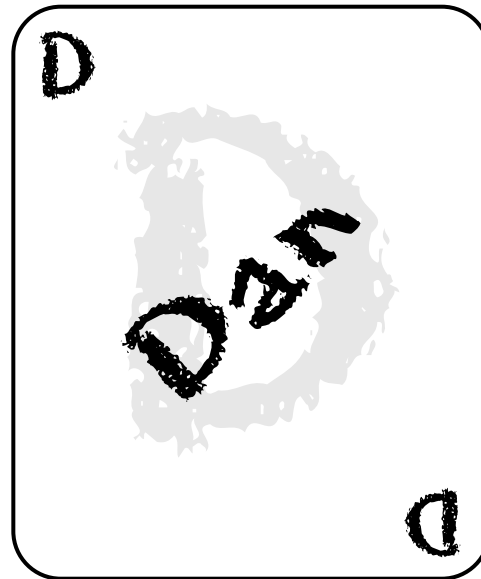
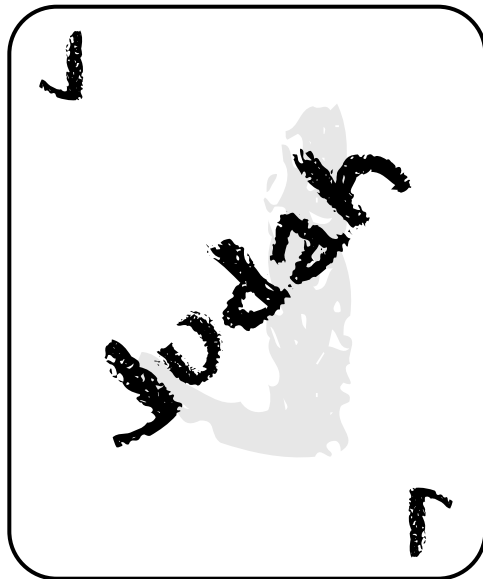
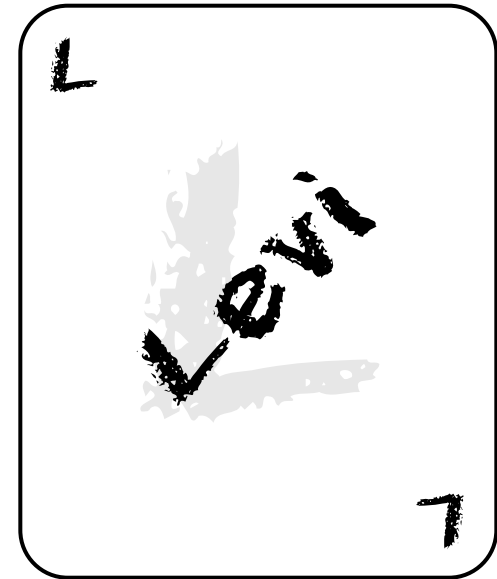
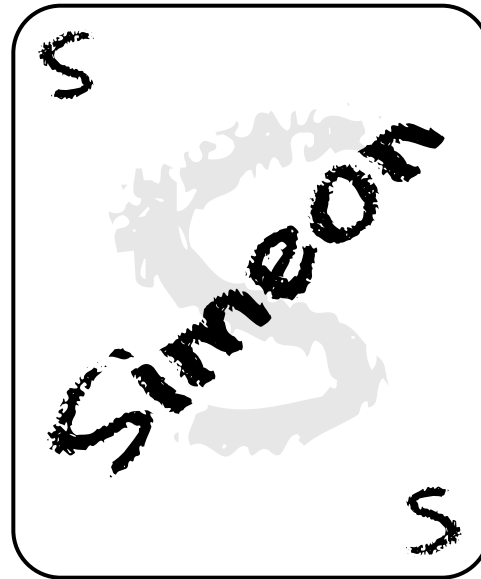
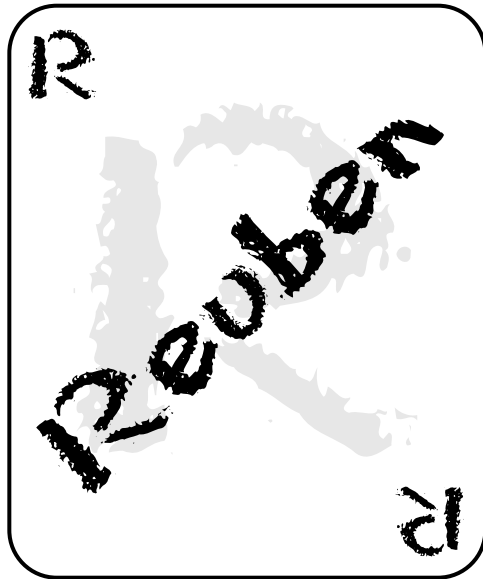

Supplement/Bible Skills
2 copies for the teacher

R
E
P
R
O
D
U
C
I
B
L
E
P
A
G
E
D

